



OE8017 - Lincat Opus 800 Electric Free-standing Induction Oven Range - W 900 mm - 24.0 kW

The Opus 800 Induction Range combines power with energy efficiency.

- ✓ Powerful 5kW, 270mm width induction zones
- ✓ Automatic pan detection function cuts power when no pan is present, preventing harm to users, while saving energy
- ✓ Multiple internal cooling fans and overheat protection for long service life
- ✓ Powerful 4kW fan assisted oven for even cooking results
- ✓ Large 3 x GN1/1 capacity oven enabling three different foods to be cooked simultaneously

Specifications

Summary

Brand	Lincat
Range	Opus 800
Power Type	Electric
Unit Type	Free-standing
Available in UK Only	No
UK Warranty	2 Years Parts and Labour Warranty
Export Warranty	Contact your local dealer
GTIN	5056105102489

Power and Performance

Total Power kW	24
Temperature Range °C	130-250
IP Rating	IP24
Cooking Area (Width x Depth) mm	260 Dia. x 4
Temperature Control	Mechanical
Rating per Hob kW	5.0
Oven Rating kW	4.0

Key Specifications

Number of Shelves included	2
Number of Shelf Positions	4
Number of Hobs	4
Shape of Hob	Round

Capacity

Gastronorm Capacity	2 x GN1/1
----------------------------	-----------

Weights and Dimensions

Unit Height (External) mm	900
Unit Width (External) mm	900
Unit Depth (External) mm	800
Height (Internal) mm	420
Width (Internal) mm	525
Depth (Internal) mm	510
Shelf Dimensions Width mm	480
Shelf Dimensions Depth mm	510
Hob Dimensions mm	270
Net Weight Kg	140

Supply Connections

Requires Installation	Yes
Requires Electrical Supply	Yes
UK 3 Pin Plug	No
Requires Hardwiring	Yes
Electrical Supply Rating Watts	24,000
Three Phase Amps	L1=34.8; L2=34.8; L3=34.8
Three Phase Voltage	400

Shipping

Packed Weight Kg	152.6
Packed Height cm	104
Packed Width cm	100
Packed Depth cm	85

Available Accessories

FI41	AIR FILTER - IH21, IH3
LK06	OPUS 800 LEG KIT

Technical Picture

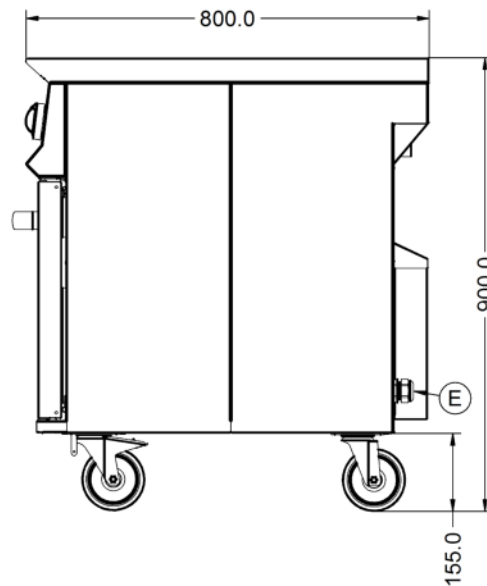
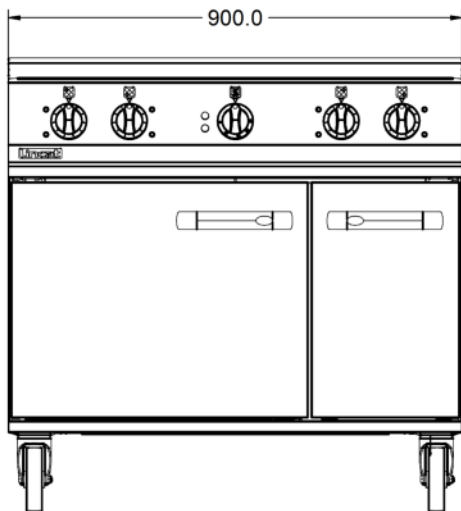
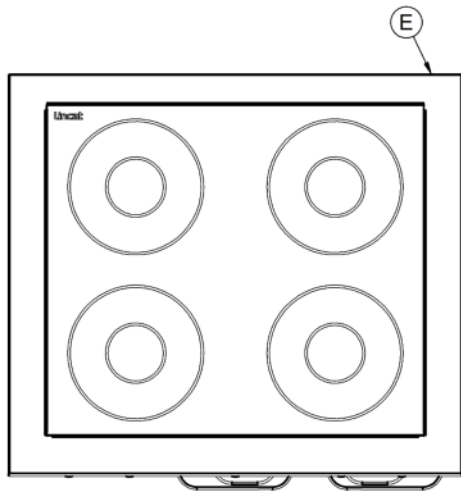

Lincat Limited

Whisby Road,
Lincoln, LN6 3QZ,
United Kingdom

Company No: 2175448

A member company of



Customer Care

Tel: +44 1522 875500
Email: care@lincat.co.uk

Export Customers

Tel: +44 1522 875536
Email: export@lincat.co.uk

Opening Hours

Monday – Friday:
8.30am – 5pm