

## Electric Fryer



**NEW  
PRODUCT**

*All Opus 700 electric fryers combine heavy-duty performance, excellent reliability, accurate control, super fast recovery, simple operation and easy cleaning. This new single tank model packs powerhouse performance and high output from the minimum of floor space.*

## **OPUS 700**



**OE7114**

## Features

- Fully welded tank and removable batter plate for ease of cleaning
- Close tolerance thermostat range 130°C to 190°C for accurate temperature control, consistent results and safe operation
- Inclined base of the tank and wide bore drain pipe, make draining down a quick and easy task
- Hinged, lift-and-park element, with safety interlock, for easy tank access and cleaning

## Inclusive Accessories

- Batter plate
- Drain spout
- Spun wire nickel plated baskets
- Tank lid

## Essential Facts & Figures

Model	Power (kW)	Width (mm)	Tank capacity (l)	No. of tanks	Tank dimensions - W x D (mm)	No. of baskets	Chips per hour*				Recommended batch weights per basket	
							Frozen		Chilled		lb	kg
OE7114	14	400	19	1	330 x 420	2	90	41	99	45	3.3	1.5

\* All output figures are for standard 7/16" chips

## Technical Specifications

Description	Single Tank Fryer
<b>Product code</b>	OE7114
Overall height (mm)	1050 - 1105
Height to hob (mm)	900 - 955
Width (mm)	400
Depth, excluding handles (mm)	737
Oil drain diameter (mm)	25
Electric power rating - kW	14
Electrical requirements	1 or 3 phase*
Voltage (1/3 phase)	230 / 400V
Amps per phase	20.3 / 20.3 / 20.3
Weight (kg)	58

\* We recommend operation on a three phase supply, where applicable

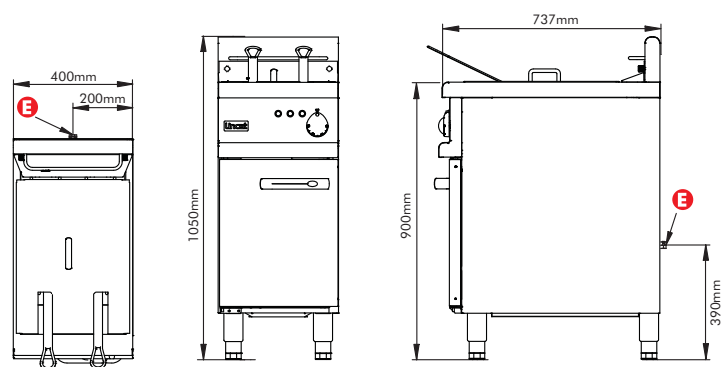

### KEY

**E** Electrical Connection



You can choose Lincat products with confidence. All Opus 700 products are backed by the reassurance of a comprehensive UK two-year parts and labour warranty.

### QUALITY GUARANTEED



**Lincat Limited, Whisby Road,  
Lincoln LN6 3QZ,  
United Kingdom**

UK Sales Tel: 01522 875500 UK Spares Tel: 01522 875510 UK General Tel: 01522 875555  
UK Fax: 01522 875530 International Sales Tel: +44 1522 503250 International Fax: +44 1522 875530  
Website: www.lincat.co.uk UK Sales e-mail: sales@lincat.co.uk International Sales e-mail: export@lincat.co.uk