

Gas Oven Ranges

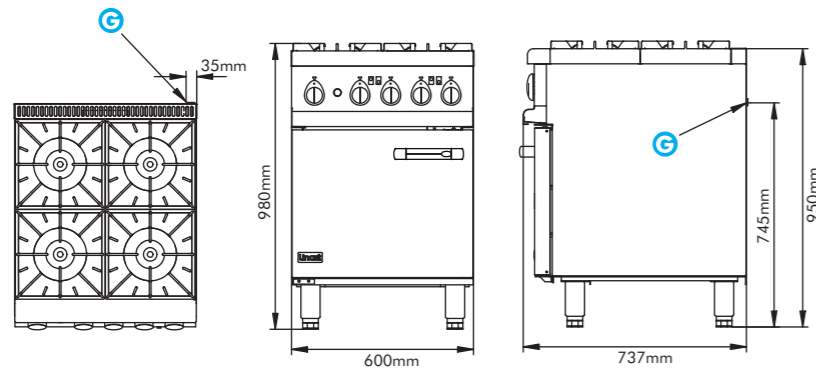

OG7001N/P

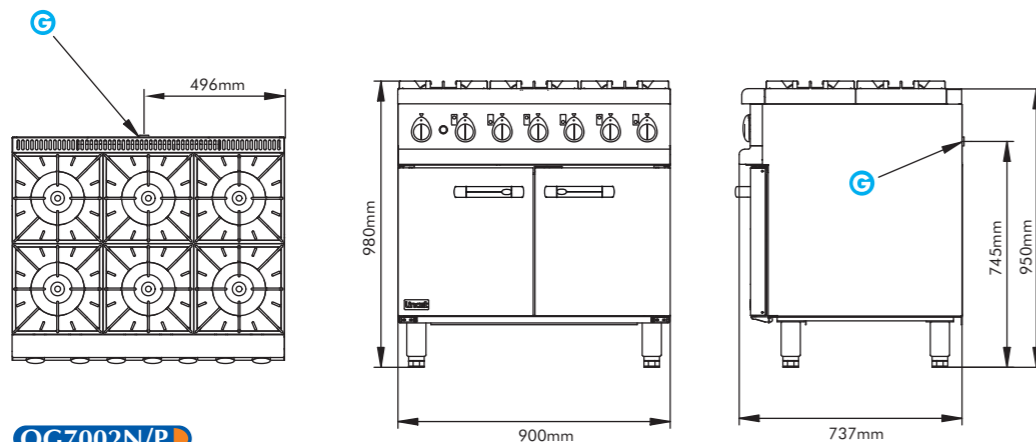

OG7002N/P

Technical Specifications

Description	4 Burner Oven Range	6 Burner Oven Range
Product Code	OG7001	OG7002
Overall height, including pan supports (mm)	950-980	950-980
Height to hob (mm)	900-930	900-930
Width (mm)	600	900
Depth, excluding handles (mm)	737	737
Gas power rating (kW) - natural	31.2	45.6
Gas power rating (kW) - propane	29.6	42.7
Gas power rating (Btu/hr) - natural	106,500	155,600
Gas power rating (Btu/hr) - propane	101,000	145,700
Gas pressure - natural	20 mbar (8" WG)	20 mbar (8" WG)
Gas pressure - propane	37 mbar (15" WG)	37 mbar (15" WG)
Gas inlet size	G 1/2 female	G 3/4 female
Weight (kg)	85	114



Opus 700 is a range of high quality prime cooking equipment designed, developed and manufactured by Lincat to meet the needs of the busiest commercial kitchen.

Opus 700 gas oven ranges are no exception. Robust and durable, these reliable four and six burner ranges deliver fast, controllable power with a stylish and easy to clean design.



**Lincat Limited, Whisby Road,
Lincoln LN6 3QZ,
United Kingdom**

QUALITY GUARANTEED

You can choose Lincat products with confidence. All products in this leaflet are backed by the reassurance of a comprehensive UK two-year parts and labour warranty.



UK Sales Tel: 01522 875500 UK Spares Tel: 01522 875510 UK General Tel: 01522 875555
UK Fax: 01522 875530 International Sales Tel: +44 1522 503250 International Fax: +44 1522 875530
Website: www.lincat.co.uk UK Sales e-mail: sales@lincat.co.uk International Sales e-mail: export@lincat.co.uk



Low-level flue



Large oven easily accommodates two 25lb turkeys



Powerful hob burners



Easy clean hob

Features

- Powerful 6.8kW (OG7001) and 9kW (OG7002) ovens
- Double insulated doors, side and back panels mean safe operation, efficiency and economy
- Four shelf positions offering greater versatility
- Precise thermostatic control from 120°C to 280°C
- Vitreous enamelled oven liners, removable floor plate and shelf supports for easy cleaning
- Powerful hob burners give true high speed cooking with controllability even at low temperature cooking
- Full depth dished hob top for ease of cleaning
- Heavy-duty cast iron twin pan supports - robust and durable
- Low-level flue to allow use of the complete hob top, with optional flue extension for uniform appearance in suites

Essential Facts & Figures

Gas Open Top Oven Ranges

Model	Oven	Hob	Total power		Rating per hob burner		Oven rating		Width (mm)	Oven internal dimensions HxWxD (mm)
			kW	Btu/hr	kW	Btu/hr	kW	Btu/hr		
OG7001/N	Gas	4 gas open burners	31.2	106,500	6.1	20,800	6.8	23,200	600	430 x 510 x 525
OG7001/P	Gas	4 gas open burners	29.6	101,000	5.7	19,400	6.8	23,200	600	430 x 510 x 525
OG7002/N	Gas	6 gas open burners	45.6	155,600	6.1	20,800	9.0	30,700	900	430 x 710 x 525
OG7002/P	Gas	6 gas open burners	42.7	145,700	5.7	19,400	8.5	29,000	900	430 x 710 x 525

Model codes ending with N or P:
 N = Natural Gas
 P = Propane Gas



Optional drop-on griddle plate



Optional splashback/plate shelf



Optional flue extension

Optional Accessories

- **OA7903** – Drop on aluminium griddle plate
- **OA7901** – Splashback/plate shelf for model OG7001
- **OA7902** – Splashback/plate shelf for model OG7002
- **OA7940** – Flue extension for model OG7001
- **OA7941** – Flue extension for model OG7002
- **OA7942** – Single pan support

Inclusive Accessories

- Piezo ignitor wand
- Two chrome plated shelves